

Serie MEDUSA II

Modelo: 5-3620-RGB-*

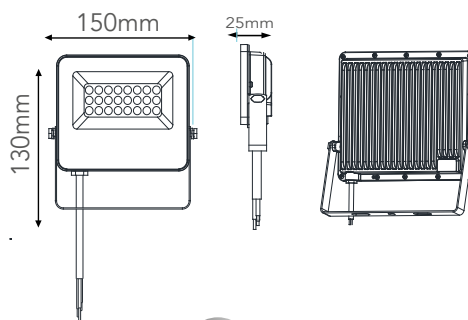

-03 Gris

Versión **RGB**

CARACTERÍSTICAS DEL PRODUCTO:

GENERAL:

DESCRIPCIÓN: REFLECTOR

TIPO DE LED: SMD3535

APERTURA: 120°

WATTS: 20W

IP: 65

TEMPERATURA DE COLOR: RGB (Cambio de color)

VIDA ÚTIL: 30,000 HRS

MATERIAL: ALUMINIO



NOTA: Control remoto incluido

ICONOGRAFÍA:

20W	SMD 3535	100- 265V	 120°	IP65	ALUM
-----	-------------	--------------	---	------	------